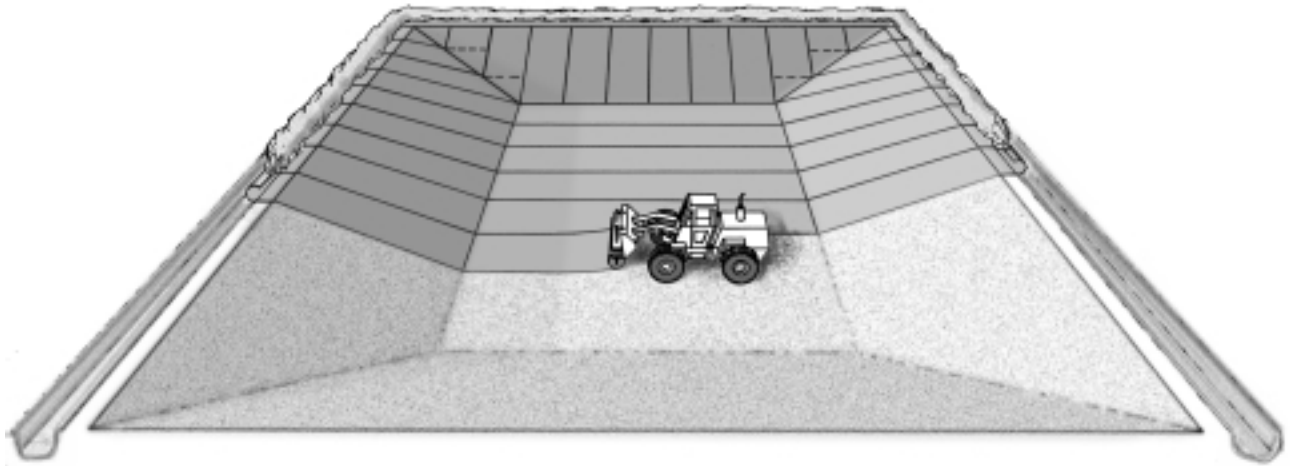


Installation Guidelines

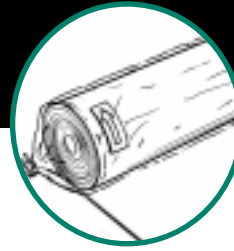


BENTOMAT[®] CLAYMAX[®]

Geosynthetic Clay Liners



TABLE OF CONTENTS



1. Introduction	3
2. Equipment Requirements	3
3. Shipping, Unloading, and Storage	5
4. Subgrade Preparation	6
5. Installation	6
6. Anchorage	9
7. Seaming	9
8. Sealing Around Penetrations and Structures	11
9. Damage Repair	14
10. Cover Placement	15
11. Hydration	15



- 1.1 This document provides procedures for the installation of CETCO's GCLs in a manner that maximizes safety, efficiency, and the physical integrity of the GCL.
- 1.2 These guidelines are based upon several years of experience at a variety of sites and should be generally applicable to any type of lining project using CETCO's GCLs. Variance from these guidelines is at the engineer's discretion.
- 1.3 The performance of the GCL is wholly dependent on the quality of its installation. It is the installer's responsibility to adhere to these guidelines, and to the project specifications and drawings, as closely as possible. It is the engineer's and owner's responsibility to provide construction quality assurance (COA) for the installation, to ensure that the installation has been executed properly. This document covers only installation procedures.

EQUIPMENT REQUIREMENTS

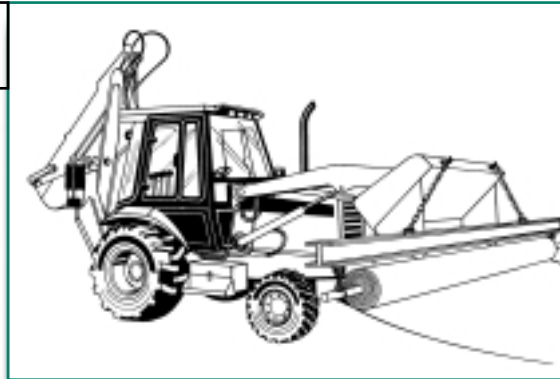
- 2.1 CETCO GCLs are delivered in rolls weighing 2,600-2,950 lbs (1180-1340 kg). It is necessary to support this weight using an appropriate core pipe as indicated in Table 1. For any installation, the core pipe must not deflect more than 3 inches (75 mm) as measured from end to midpoint when a full GCL roll is lifted.

TABLE 1 CORE REQUIREMENTS

Product(s)	Nominal GCL Roll Size W x Dia. Ft. (m) x in. (mm)	Typical GCL Roll Wt., lbs. (kg)	Interior Core Size, in. (mm)	Core Pipe Length x Diameter, ft. x in. (m x mm)	Minimum Core Pipe Strength
Bentomat CL, DN, SDN	16' x 24" (4.9 x 610)	2,650 (1200)	3 3/4 (100)	20 x 2.88" O.D. (6.1 cm x 73.1mm)	XXH
Bentomat ST	16' x 24" (4.9 x 610)	2,600 (1180)	3 3/4 (100)	20 x 2.88" O.D. (6.1 cm x 73.1mm)	XXH
Bentomat CLT	16' x 26" (4.9 x 660)	2,950 (1340)	3 3/4 (100)	20 x 2.88" O.D. (6.1 cm x 73.1mm)	XXH
Claymax 200R, 600CL	16' x 20" (4.9 x 510)	2,750 (1250)	3 3/4 (100)	20 x 2.88" O.D. (6.1 cm x 73.1mm)	XXH

- 2.2 Lifting chains or straps appropriately rated should be used in combination with a spreader bar made from an I-beam as shown in Figure 1.

FIGURE 1 SPREADER BAR LIFTING ASSEMBLY



- 2.3 The spreader bar ensures that lifting chains or straps do not chafe against the ends of the GCL roll, allowing it to rotate freely during installation. Spreader bar and core pipe kits are available through CETCO.
- 2.4 A front end-loader, backhoe, dozer, or other equipment can be utilized with the spreader bar and core pipe or slings. Alternatively, a forklift with a “stinger” attachment may be used for on-site handling and, in certain cases, installation. A forklift without a stinger attachment should not be used to lift or handle the GCL rolls. Stinger attachments (shown in Figures 2-4) are specially fabricated to fit various forklift makes and models.

FIGURE 2 HOOK MOUNT

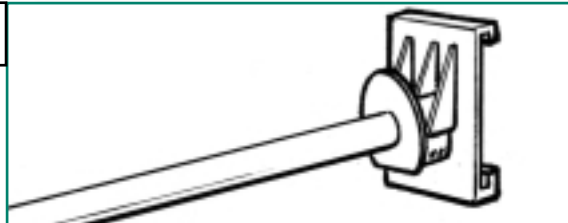


FIGURE 3 FORK MOUNT (with fork pockets)

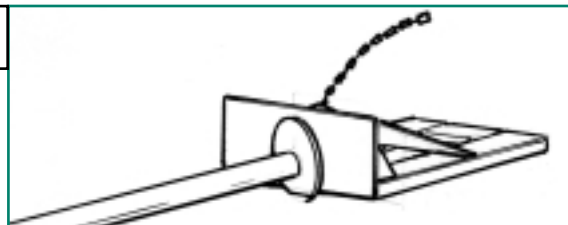
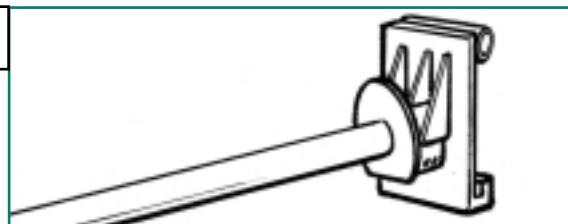


FIGURE 4 PIN MOUNT





- 2.5 When installing over certain geosynthetic materials, a 4-wheel, all-terrain vehicle (ATV) can be used to deploy the GCL. An ATV can be driven directly on the GCL provided that no sudden stops, starts, or turns are made.
- 2.6 Additional equipment needed for installation of CETCO's GCLs includes:
 - Utility knife and spare blades (for cutting the GCL).
 - Bentonite mastic (for sealing around structures and details) and/or granular bentonite (for end-of-roll seams of GCLs with needle-punched, non-woven geotextiles and for sealing around structures and details). Both are available from CETCO.
 - Waterproof tarpaulins (for temporary cover on installed material as well as for stockpiled rolls).
 - Optional flat-bladed vise grips (for positioning the GCL panel by hand).

3

SHIPPING, UNLOADING & STORAGE

- 3.1 All lot and roll numbers should be recorded and compared to the packing list. Each roll of GCL should also be visually inspected during unloading to determine if any packaging has been damaged. Damage, whether obvious or suspected, should be recorded and marked.
- 3.2 Major damage suspected to have occurred during transit should be reported immediately to the carrier and to CETCO. The nature of the damage should also be indicated on the bill of lading with the specific lot and roll numbers.
- 3.3 The party directly responsible for unloading the GCL should refer to this manual prior to shipment to ascertain the appropriateness of their unloading equipment and procedures. Unloading and on-site handling of the GCL should be supervised to ensure these goals are achieved. Roll dimensions and weights will vary with the dimensions of the product ordered.
- 3.4 In most cases, CETCO GCLs are delivered on flatbed trucks. There are three methods of unloading; core pipe and spreader bar, slings or stinger bar. To unload the rolls from the flatbed using a core pipe and spreader bar, first insert the core pipe through the core tube. Secure the lifting chains or straps to each end of the core pipe and to the spreader bar mounted on the lifting equipment. Hoist the roll straight up and make sure its weight is evenly distributed so that it does not tilt or sway when lifted.
- 3.5 CETCO GCLs can be delivered with two 2" x 12' Type V polyester endless slings on each roll. Before lifting, check the position of the slings. Each sling should be tied off in the choke position approximately 1/3 the way in from the end of the roll. Hoist the roll straight up so that it does not tilt or sway when lifted.
- 3.6 In some cases, GCL rolls will be stacked in three pyramids on flatbed trucks. If slings are not used rolls will require unloading with a stinger bar and extendible boom fork lift. Spreader bars will not work in this situation because of the limited distance between the pyramids of GCL. Three types of stinger bars are available from CETCO (refer to Figures 2-4). To unload GCL rolls oriented like this, guide the stinger bar as far as possible through the core tube before lifting the GCL roll and unloading from the truck.



- 3.7 Rolls should be stored at the job site away from high-traffic areas but sufficiently close to the active work area to minimize handling. The designated storage area should be flat, dry and stable. Moisture protection of the GCL is provided by its packaging; however, an additional tarpaulin or plastic sheet is recommended.
- 3.8 Rolls should be stacked in a manner that prevents them from sliding or rolling. This can be accomplished by frequent chocking of the bottom layer of rolls. Rolls should be stacked no higher than the height at which they can be safely handled by laborers (typically no higher than four layers or rolls). Rolls should never be stacked on end.

4

SUBGRADE PREPARATION

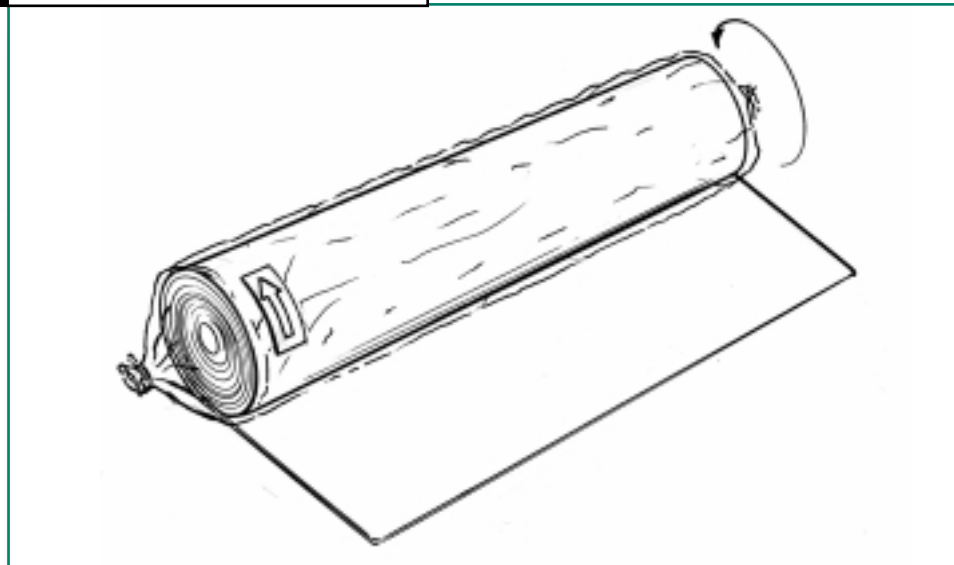
- 4.1 Subgrade surfaces consisting of granular soils or gravel may not be acceptable due to their large void fracture and puncture potential. In high head (greater than one foot) applications subgrade soils should possess a particle size distribution such that at least 80 percent of the soil is finer than a #60 sieve (0.250 mm) unless a membrane laminated GCL Bentomat CL, Bentomat CLT, or Claymax CL is used.
- 4.2 When the GCL is placed over an earthen subgrade, the subgrade surface must be in accordance with the project specifications. Engineer's approval of the subgrade must be obtained prior to installation. The finished surface should be firm and unyielding, without abrupt elevation changes, voids, cracks, ice, or standing water.
- 4.3 The subgrade surface must be smooth and free of vegetation, sharp-edged rocks, stones, sticks, construction debris, and other foreign matter that could contact the GCL. The subgrade should be rolled with a smooth-drum compactor to remove any wheel ruts, footprints, or other abrupt grade changes. Furthermore, all protrusions extending more than 0.5 inch (12 mm) from the subgrade surface shall be removed, crushed, or pushed into the surface with a smooth-drum compactor. The GCL may be installed on a frozen subgrade, but the subgrade soil in the unfrozen state should meet the above requirements.

5

INSTALLATION

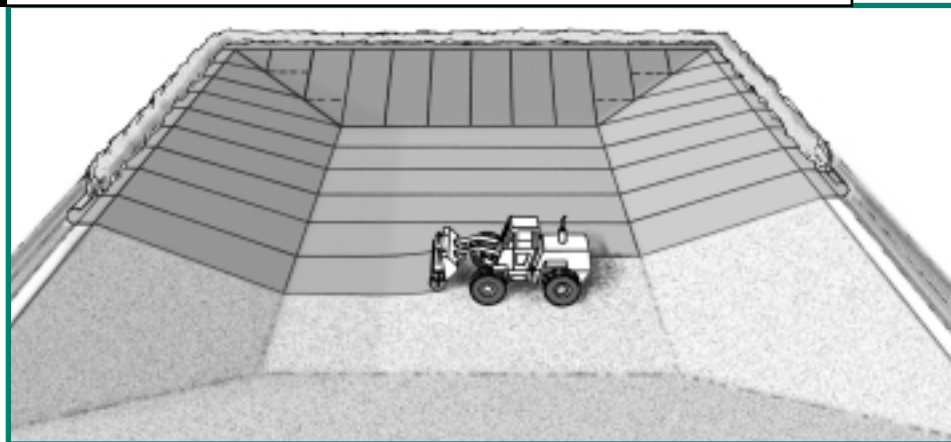
- 5.1 GCL rolls should be taken to the work area of the site in their original packaging. The orientation of the GCL (i.e., which side faces up) may be important if the GCL has two different types of geosynthetics. Unless otherwise specified the GCL is deployed with the outward side down. The arrow sticker on the plastic sleeve indicates the direction the roll will unwind when placed on the ground, (see figure 5). Prior to deployment, the packaging should be carefully removed without damaging the GCL.

FIGURE 5 DIRECTION TO UNROLL GCL



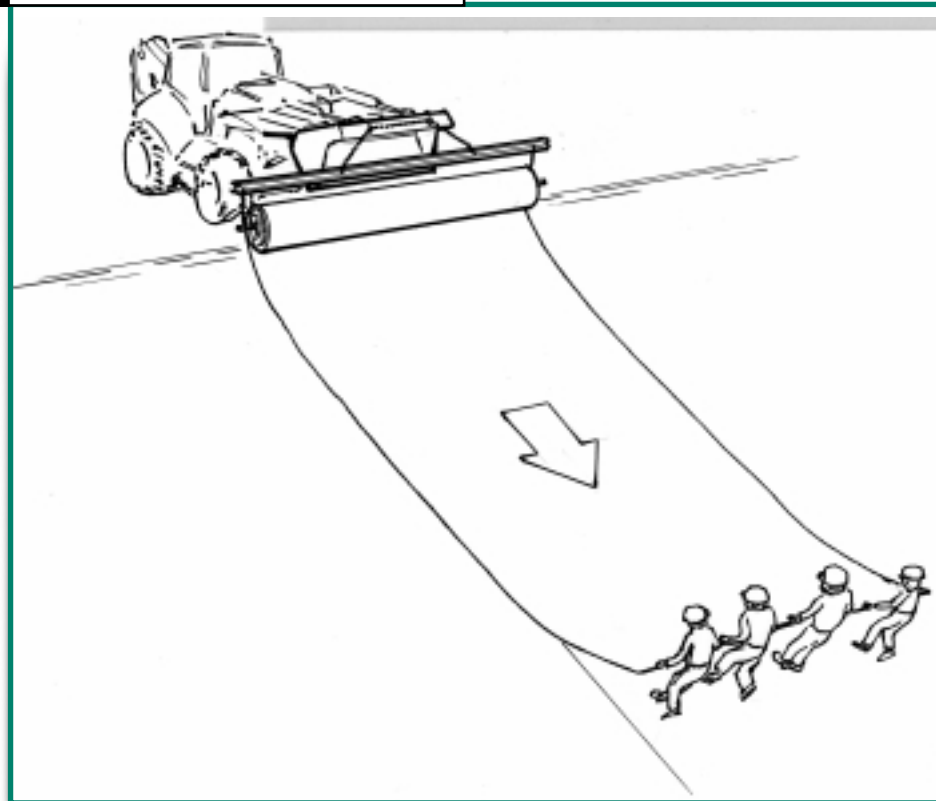
- 5.2 Equipment which could damage the GCL should not be allowed to travel directly on it. Acceptable installation, therefore, may be accomplished such that the GCL is unrolled in front of the backwards-moving equipment (Figure 6). If the installation equipment causes rutting of the subgrade, the subgrade must be restored to its originally accepted condition before placement continues.

FIGURE 6 TYPICAL BENTOMAT®/CLAYMAX® INSTALLATION TECHNIQUE



- 5.3 If sufficient access is available, GCL may be deployed by suspending the roll at the top of the slope with a group of laborers pulling the material off of the roll and down the slope (see Figure 7).
- 5.4 GCL rolls should not be released on the slope and allowed to unroll freely by gravity.
- 5.5 Care must be taken to minimize the extent to which the GCL is dragged across the subgrade in order to avoid damage to the bottom surface of the GCL. Care must also be taken when adjusting Bentomat CLT panels to avoid damage to the geotextile surface of one panel of GCL by the textured sheet of another panel of GCL. A temporary geosynthetic subgrade covering commonly known as a slip sheet or rub sheet may be used to reduce friction damage during placement.

FIGURE 7 UNROLLING BENTOMAT

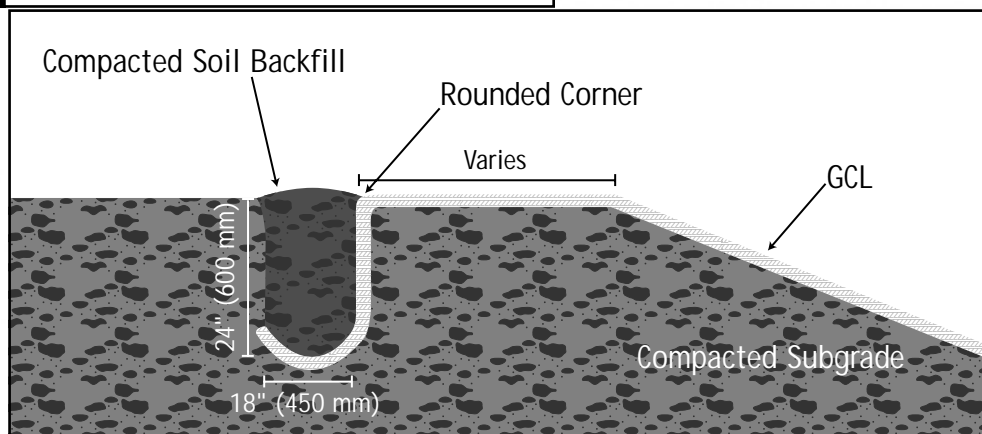


- 5.6 The GCL should be placed so that seams are parallel to the direction of the slope. End-of-roll seams should also be located at least 3 ft (1m) from the toe and crest of slopes steeper than 4H: 1V. End-of-roll seams should be used only if the liner is not expected to be in tension when installed on slopes.
- 5.7 All GCL panels should lie flat on the underlying surface, with no wrinkles or folds, especially at the exposed edges of the panels. When Bentomat with SuperGroove® is repositioned it should be gripped inside the SuperGroove by folding the edge.
- 5.8 The GCL should not be installed in standing water or during rainy weather. Only as much GCL shall be deployed as can be covered at the end of the working day with soil, a geomembrane, or a temporary waterproof tarpaulin. The GCL shall not be left uncovered overnight. If the GCL is hydrated when no confining stress is present, it may be necessary to remove and replace the hydrated material. The project engineer and COA inspector should be consulted for specific guidance if premature hydration occurs.
- 5.9 For the convenience of the installer, hash marks are placed approximately every 5' of length of Bentomat.

ANCHORAGE

- 6.1 If required by the project drawings, the end of the GCL roll should be placed in an anchor trench at the top of a slope. The front edge of the trench should be rounded to eliminate any sharp corners that could cause excessive stress on the GCL. Loose soil should be removed or compacted into the floor of the trench.
- 6.2 If a trench is used for anchoring the end of the GCL, soil backfill should be placed in the trench to provide resistance against pullout. The size and shape of the trench, as well as the appropriate backfill procedures, should be in accordance with the project drawings and specifications. Typical dimensions are shown in Figure 8.
- 6.3 The GCL should be placed in the anchor trench such that it covers the entire trench floor but does not extend up the rear trench wall.

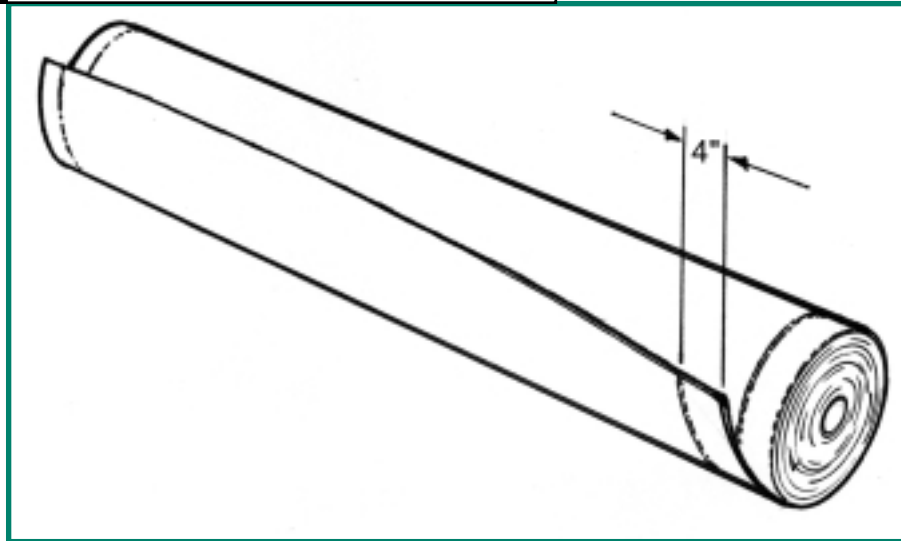
FIGURE 8 TYPICAL ANCHOR TRENCH DESIGN



- 6.4 Sufficient anchorage may alternately be obtained by extending the end of the GCL roll back from the crest of the slope, and placing cover soil. The length of this "runout" anchor is project-specific.

SEAMING

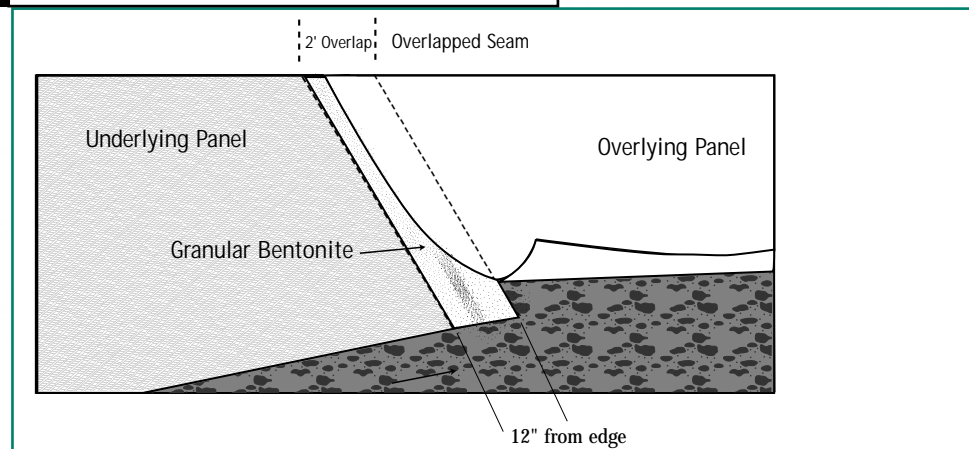
- 7.1 GCL seams are constructed by overlapping their adjacent edges. Care should be taken to ensure that the overlap zone is not contaminated with loose soil or other debris. Supplemental bentonite is not required for Claymax 200R, 600CL. Bentomat ST, SDN, or DN with Supergroove provides self-seaming (See Figure 9) without the need for supplemental bentonite. Bentomat CL and CLT require bentonite enhanced seams. For pond applications CETCO recommends using supplemental bentonite in longitudinal seams irregardless of the CETCO GCL being used.

FIGURE 9**SUPERGROOVE**

- 7.2 End-of-panel overlapped seams should overlap 24 inches (600 mm).
- 7.3 End-of-panel overlapped seams, should be constructed such that they are shingled in the direction of the grade to prevent runoff flow from entering the overlap zone. End-of-panel seams on slopes are permissible; provided adequate slope stability analysis has been conducted (i.e. the GCL is not expected to be in tension). Bentonite-enhanced seams are required for Bentomat end-of-panel overlapped seams.
- 7.4 End-of-panel overlapped seams are constructed first by overlapping the adjacent panels, exposing the underlying panel, and then applying a continuous bead or fillet of granular sodium bentonite (supplied with the GCL) 12" from the edge of the underlying panel (See Figure 10) from the end-of-roll. The minimum application rate at which the bentonite is applied is one quarter pound per linear foot (0.4 kg/m).
- 7.5 If longitudinal bentonite enhanced seams are required, they are constructed first by overlapping the adjacent panels by a minimum 6-inches (150 mm), exposing the underlying edge and applying a continuous bead of granular bentonite approximately 3-inches (75 mm) from the edge. The minimum application rate for the granular bentonite is one quarter pound per linear foot (0.4 kg/m).



FIGURE 10 END-OF-PANEL OVERLAPPED SEAM



8

SEALING AROUND PENETRATIONS AND STRUCTURES

- 8.1 Cutting the GCL should be performed using a sharp utility knife. Frequent blade changes are recommended to avoid irregular tearing of the geotextile components of the GCL during the cutting process.
- 8.2 The GCL should be sealed around penetrations and structures embedded in the subgrade in accordance with Figures 11 through 13. Granular bentonite or a bentonite mastic shall be used liberally (approx. 2 lbs. /In ft. or 3 kg/m) to seal the GCL to these structures.

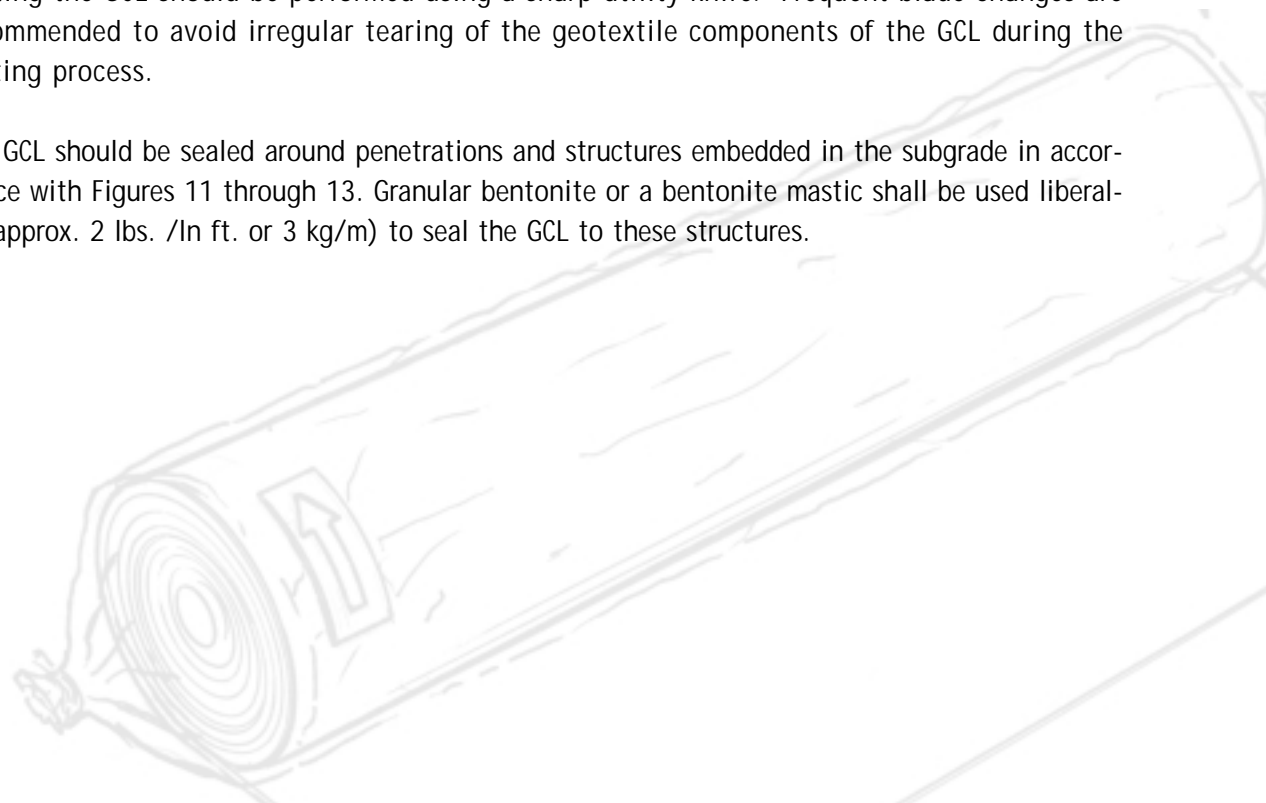




FIGURE 11A. CROSS-SECTION OF A HORIZONTAL PIPE PENETRATION

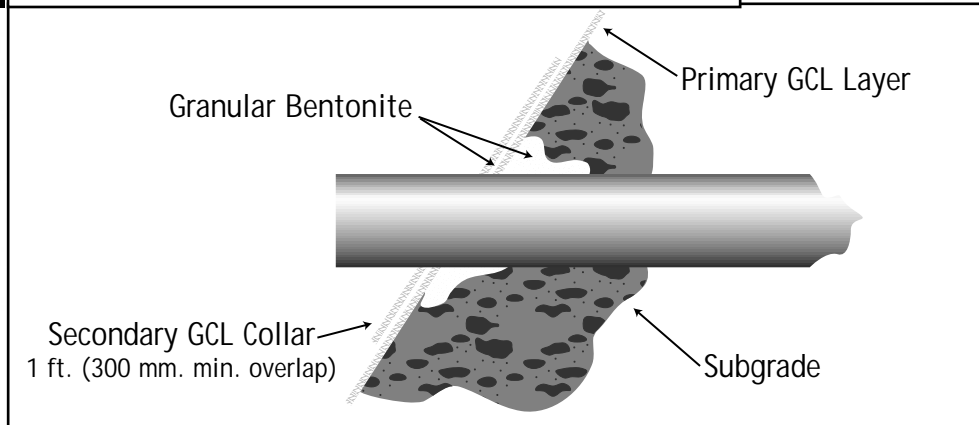
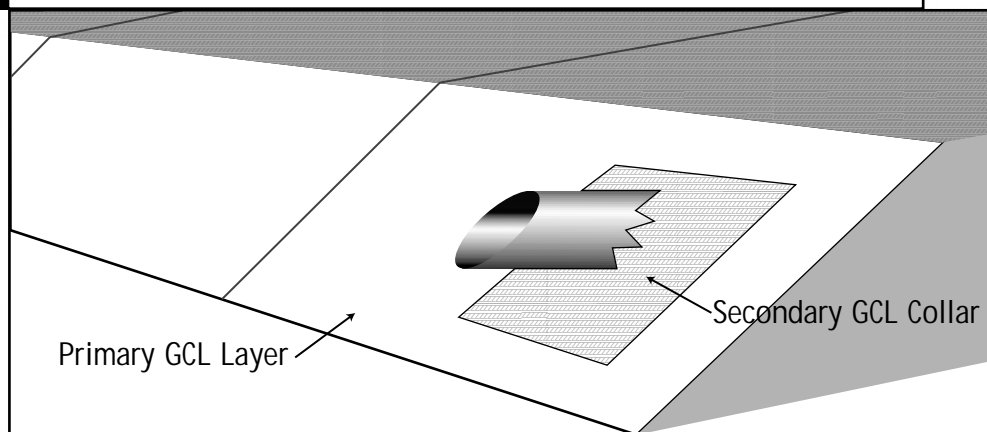


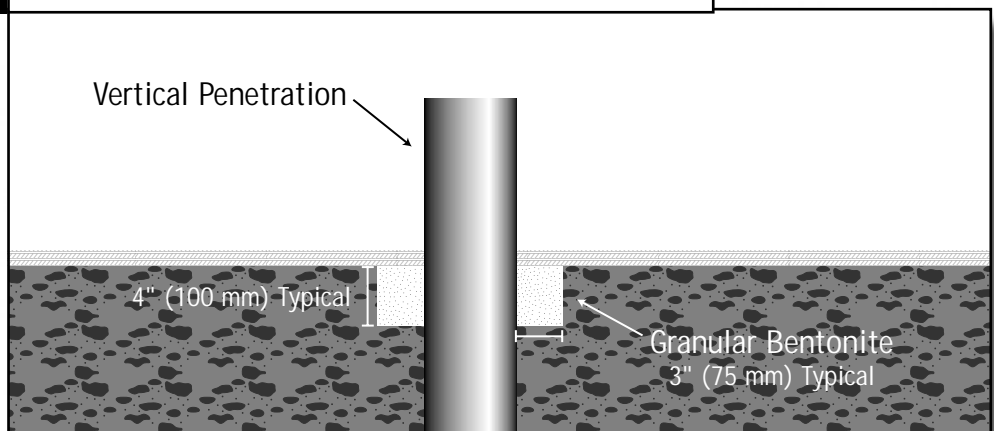
FIGURE 11B ISOMETRIC VIEW OF A COMPLETED HORIZONTAL PIPE PENETRATION



- 8.3 When the GCL is placed over a horizontal pipe penetration, a “notch” should be excavated into the subgrade around the penetration (Figure 11a). The notch should then be backfilled with granular bentonite. A secondary collar of GCL should be placed around the penetration as shown in Figure 11b. It is helpful to first trace an outline of the penetration on the GCL and then cut a “star” pattern in the collar to enhance the collar’s fit to the penetration. Granular bentonite should be applied between the primary GCL layer and the secondary GCL collar.

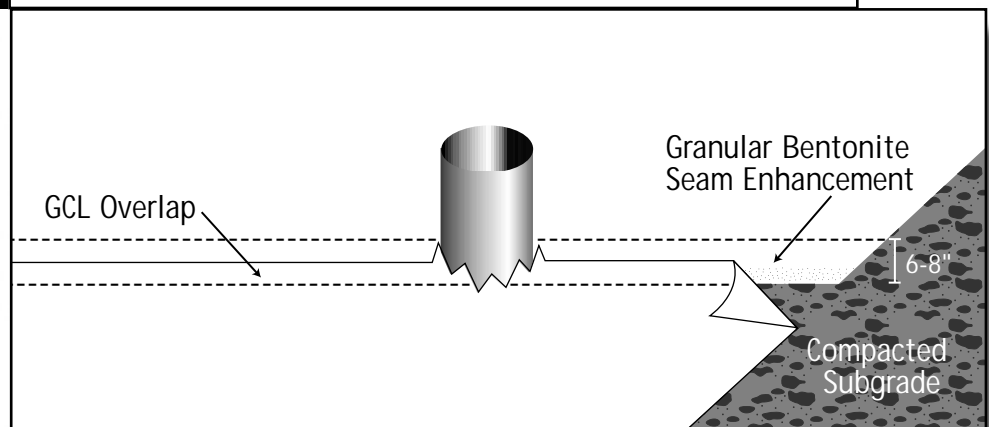


FIGURE 12A. CROSS-SECTION OF A VERTICAL PENETRATION



- 8.4 Vertical penetrations are prepared by notching into the subgrade as shown in Figure 12a. The penetration can be completed with two separate pieces of GCL as shown in Figure 12b. Alternatively, a secondary collar can be placed as in Figure 11a or 11b.

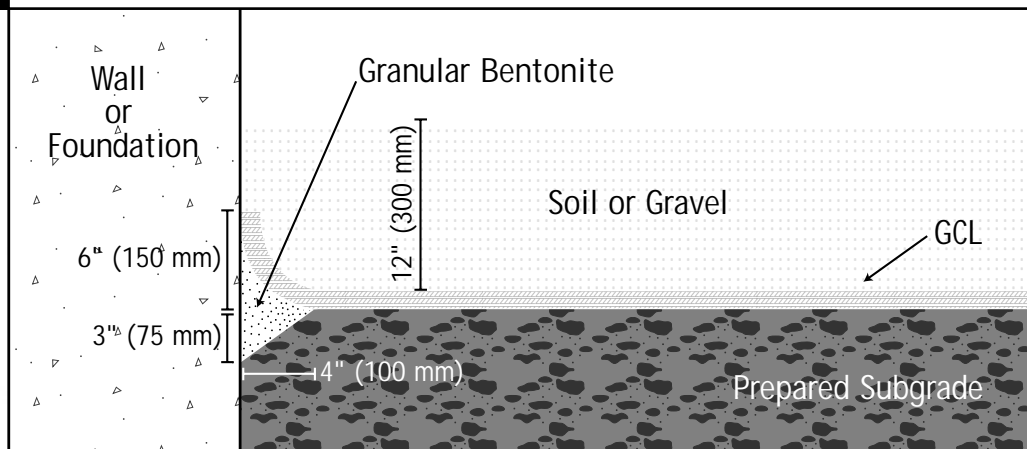
FIGURE 12B. ISOMETRIC VIEW OF THE COMPLETED VERTICAL PENETRATION



- 8.5 When the GCL is terminated at a structure or wall that is embedded into the subgrade on the floor of the containment area, the subgrade should be notched as described in sections 8.3 and 8.4. The notch is filled with granular bentonite, and the GCL should be placed over the notch and up against the structure (Figure 13). The connection to the structure can be accomplished by placement of soil or stone backfill in this area. When structures or walls are on or at the top of a slope, additional detailing may be required. Contact CETCO's Technical Support Services for project specific guidance.



FIGURE 13. CROSS-SECTION OF GCL SEAL AGAINST AN EMBEDDED STRUCTURE OR WALL

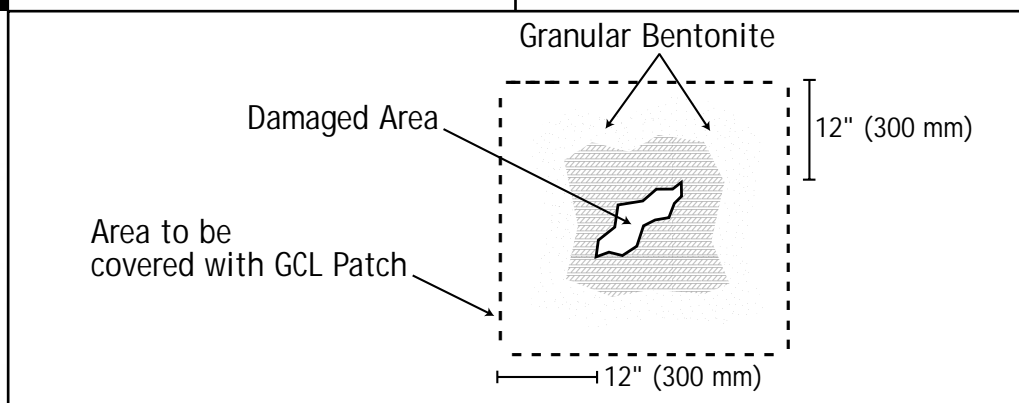


9

DAMAGE REPAIR

- 9.1 If the GCL is damaged (torn, punctured, perforated, etc.) during installation, it may be possible to repair it by cutting a patch to fit over the damaged area (Figure 14). The patch should be cut to size such that a minimum overlap of 12 inches (300 mm) is achieved around all parts of the damaged area. Granular bentonite or bentonite mastic should be applied around the damaged area prior to placement of the patch. It may be necessary to use an adhesive such as wood glue to affix the patch in place so that it is not displaced during cover placement. Smaller patches also may be tucked under the damaged area to prevent patch movement.

FIGURE 14. DAMAGE REPAIR BY PATCHING





10

COVER SEAL

- 10.1 The final thickness of soil cover on the GCL varies with the application. A minimum cover layer must be at least 1 foot (300 mm) thick to provide confining stress to the GCL and prevent damage by equipment, erosion, etc.
- 10.2 Cover soils should be free of angular stones or other foreign matter that could damage the GCL. Cover soils should be approved by the Engineer with respect to particle size, uniformity, and chemical compatibility. Consult your CETCO representative if cover soils with high concentrations of calcium (e.g., limestone, dolomite, gypsum, seashell fragments) are present.
- 10.3 Recommended cover soils should have a particle size distribution ranging between fines and 1 inch (25 mm), unless a cushioning geotextile is specified.
- 10.4 Soil cover shall be placed over the GCL using construction equipment that minimizes stresses on the GCL. A minimum thickness of 1 foot (300 mm) of cover soil should be maintained between the equipment tires/tracks and the GCL at all times during the covering process. In frequently high traffic areas or roadways, a minimum thickness of 2 feet (600 mm) is required.
- 10.5 Soil cover should be placed in a manner that prevents the soil from entering the GCL overlap zones. Soil cover should be pushed up slopes, not down slopes, to minimize tensile forces on the GCL.
- 10.6 When a textured geomembrane is installed over the GCL, a temporary geosynthetic covering known as a slip sheet or rub sheet should be used to minimize friction during placement and to allow the textured geomembrane to be more easily moved into its final position.

11

HYDRATION

- 11.1 In cases where the containment of non-aqueous liquid is required, it may be necessary to hydrate the covered GCL with water prior to use. Hydration is usually accomplished by natural rainfall and/or absorption of moisture from soil.
- 11.2 If manual hydration is necessary, water can be introduced by flooding the covered lined area or using a sprinkler system.





NOTICE: This document is intended for use as a GENERAL GUIDELINE for the installation of CETCO's GCLs. The information and data contained herein are believed to be accurate and reliable. CETCO makes no warranty of any kind and accepts no responsibility for the results obtained through application of this information.

1500 West Shure Drive Arlington Heights, IL 60004-1440 TEL 800.527.9948 FAX 847.577.5571

©2003, CETCO