

“SLIDES HAPPEN - LANDFILL STABILITY ANALYSIS”

PRESENTED TO

**CIVIL ENGINEERING DEPARTMENT
NORTH CAROLINA STATE UNIVERSITY
RALEIGH, NC
APRIL 20, 2004**

**ALSO GIVEN AS
THE 2002 ALEKSANDAR VESIC MEMORIAL LECTURE**



PRESENTED TO

**NORTH CAROLINA SECTION
AMERICAN SOCIETY OF CIVIL ENGINEERS**

**WRIGHTSVILLE BEACH, NC
OCTOBER 3, 2002**

BY

**DR. GORDON P. BOUTWELL, P.E.
SOIL TESTING ENGINEERS, INC.
BATON ROUGE, LA - NEW ORLEANS, LA - BILOXI, MS**

SLIDES HAPPEN - LANDFILL STABILITY ANALYSIS

Gordon P. Boutwell, Jr., President

Soil Testing Engineers, Inc., Baton Rouge, LA, USA

DEDICATION

We are gathered to honor the achievements of our colleague and friend, Dr. Robert M. Koerner. Yet, with his characteristic humility, he asked that I honor a different man, one who was friend and mentor to the both of us: the late Dr. Aleksandar S. Vesic. After all, Bob and I met because of Dr. Vesic.

Let's go back almost 40 years, to the early spring of 1965. I was working in Baton Rouge, had a house, 2 cars, and an interesting job in geotechnical engineering. Then - I got a call from Dr. Vesic, under whom I had studied at Georgia Tech. He wanted me to leave this good life and come back to school: back to the life of a penniless student! I hesitated about a nanosecond, and asked him when the semester started. So, that fall, I arrived at Duke University.

One of my new classmates was a Yankee from Philadelphia, who had also been out in the world of practice: Bob Koerner. I came to Duke off a drill rig, he came off a dredge. Somehow, our different accents and home areas didn't matter - we became close friends and remain so. He even managed to down a full bowl of my four-alarm chili (through courtesy, probably). At Duke, both Bob and I worked in the field of particulate matter strength parameters. Together, we built Duke's triaxial testing laboratory, which served them for 35 years. He was into friction of pure minerals, I was in Critical State. Bob was grinding pound after pound of various minerals to dust and evaluated their strength characteristics by triaxial testing. After Duke, he worked in a similar field, powdered metals. Then, he met geosynthetics, and, as they say, "*The rest is history.*" Before we left Duke, we promised each other that we would trade jobs for 6 months every five years. Unfortunately, neither of us was able to live up to that agreement.

But, enough of our student days. The real honor is owed to the memory of the man who made our friendship possible: Dr. Aleksandar Sedmak Vesic. In words from Abraham Lincoln's **Gettysburg Address**, "*it is altogether fitting and proper that we should do this.*" Dr. Vesic was born in Yugoslavia (1924), and received his PhD from Belgrade. He finished first in his class, and second was a lovely blond who decided "*if you can't beat him, join him*" and married him. They moved to Ghent, where he taught at the Belgian Geotechnical Institute. There he developed his groundbreaking work in bearing capacity and in beams on fully-elastic subgrades. He came to Georgia Tech in 1958, and soon revolutionized pile capacity analysis. In 1963, he accepted a full professorship at Duke University; some of his work at Duke made analysis of excavation by explosive means a reliable science. In the classes Bob and I attended, Dr. Vesic would often fill the blackboard with equations and concepts. Then, he'd say "*This is what we thought before. But last night I found out that...*" and fill the blackboard again! He also created a major symposium on foundation engineering at Duke in 1965. Although he had only been in the US for seven years, "*everybody who was anybody*" in soil mechanics presented or attended. I recently saw Dr. Ralph Peck at an ASCE conference and he remembered the Duke Symposium. Dr. Vesic served on many national boards and committees, including the Highway Research Board. His

international honors included lecturing at Cambridge University and receiving an honorary doctorate from his old school at Ghent.



FIGURE 1
DR. A. S. VESIC (Right) AND HIS STUDENT, BOB KOERNER
DUKE UNIVERSITY, 1966

Dr. Vesic rose to Chairman of Duke's Civil Engineering Department, then to Dean of its School of Engineering in 1974. He held that position until his untimely death in 1982. Mrs. Vesic is still active in the engineering community.

A good measure of a man's greatness is his effect on the lives and careers of others. Some of Dr. Vesic's students included:

Dr. G. Wayne Clough, P.E. - President of Georgia Tech

Dr. J. Michael Duncan, P.E. - "Mr. Slope Stability,"

University Distinguished Professor at Virginia Tech

Dr. Robert M. Koerner, P.E. - "Mr. Geosynthetics,"

Director of the Geosynthetic Institute

The late Dr. Surendra K. Saxena - Then Chairman of Civil Engineering, Illinois Tech

INTRODUCTION

Several years ago, your Author had one of his papers on clay liners for sanitary landfills in a particular publication. Dr. Koerner had a paper on synthetic liners in the same issue. We first thought that our mentor, Dr. Aleksandar Vesic, would be proud that two of his former students published in the same

issue of that journal. Or, would he have considered us a couple of garbagemen? No, he would have recognized the importance of waste disposal to our society. Consider this:

- You may not need a fireman during your whole life.
- You (hopefully) may not need a policeman often during your life.
- You need the garbage man once a week.

Most of your household garbage today goes to a sanitary landfill. This is an engineered repository for that garbage with various environmental protection features. It also forms a junior-grade mountain. A relatively small (100 Acre) landfill has a capacity 4 to 6 times the volume of the Great Pyramid at Gizeh. As a look at the Ruined Pyramid at Meidum tells us, even stone pyramids can collapse; so can our garbage mountains. The engineer designing a landfill must consider the stability of its slopes. Since Dr. Koerner and your Author have both worked in the field of waste mass stability, he asked that your Author speak on this topic.

IMPORTANCE OF LANDFILL STABILITY

Two competing slope considerations must be balanced for successful design of a waste facility:

- Flat side slopes are more stable, so that a facility with flatter side slopes is less likely to have a damaging “landslide.” You sleep better, but at the expense of your client.
- Steep side slopes allow more volume for a given size of facility. Volume, or “airspace,” is all that a waste facility has for sale. Your client wants to maximize airspace.

Hence, a good stability analysis is needed to avoid costly overconservatism or (possibly) even more costly slope failures. As an example, let’s look at a 100-acre landfill for Municipal Solid Waste (MSW). Side slopes of 1(V):5(H) will be very stable, but yield a usable volume of around 13 million cubic yards. If you can use 1(V):3(H) side slopes, the stability is reduced but the volume increases by 6 million cubic yards, an increase in value of some \$120,000.000.

But, will the steeper slope be stable? We’ll look first at the consequences of a slide, then at some slides which have happened, and then at the analyses we make to evaluate stability.

WASTE SLIDES CAN HURT YOU

A slide is an uncontrolled movement of soil (landslide) or waste (waste slide) down a slope. A slide is a slope failure; lack of stability. Federal and state regulations state that landfills cannot be located in an unstable area without a demonstration of stability, and most regulators require you to show that the side slopes of your waste facility will be stable. There is a good reason for these requirements; the consequences of a slide can be damaging to the environment:

- ! The liners can be torn, maybe causing groundwater pollution.
- ! Wastes can be released outside the unit boundaries.
- ! Odor or other air quality problems can result.

And, the necessary remediation/reconstruction can be quite expensive. The reputations of those responsible will also be damaged.

WASTE SLIDES HAVE HAPPENED

The vast majority of waste facilities have not had slides. However, there have been enough failures to tell us not only *that* they occur, but also *how* they occur. These lessons from the field help us guard against future slides. A few cases and what they taught the engineering profession are summarized below. Unfortunately, some people haven't learned yet and several of these real failure cases are fairly recent.

MSW Facility - Southern US (1997). Here, weak cover soil dredged from a sedimentation pond was placed parallel to the exterior slope (against the original design recommendation) and covered with 15 feet of Municipal Solid Waste (MSW). The slope failed at the waste/soil interface, sending 26,000 cubic yards of waste downhill. Lesson: Follow the design when you build. As a historic note, this lesson was not learned very well. Similar slides occurred at this facility for the same reason on two subsequent occasions.

NHIW Facility - North Central US (1997). A weak non-hazardous industrial waste (NHIW) was placed on a slope steeper and taller than the design. The mass failed within the waste. Some 200,000 cubic yards moved, and some escaped the facility, getting into "wetlands," subject to Corps of Engineers jurisdiction. The Corps was not a happy camper. Lessons: Failures can occur in the waste mass; follow the design.

Sludge Facility - Pacific Northwest (1998). Here, papermill sludge was being deposited *hydraulically*. The waste mass exhibited both classical failures and viscous flow slides. Lesson: Don't expect a fluid to stand on a slope; drain or pre-dry high water content materials.

MSW Facility - Midwestern US (1996). Here, a strong MSW slid in a weak plane in the natural soil. The failure moved some 1.5 million cubic yards of MSW. Lessons: Failures can occur in the foundation soil; consider the weakest layer; MSW and soil may not have their maximum strengths acting at the same time. The slide area was rebuilt after residual-strength analyses, and was still stable when the Author visited the site in 2002.

HW Facility - Western US (1988). Some 600,000 cubic yards of Hazardous Waste (HW) slid along the interface between the slick plastic geomembrane liner and the native soil. Lesson: Synthetics and their interfaces can be planes of weakness.

HW Facility - Southeastern US (1985). The operator cut a 20 foot vertical face at the toe of a 40 foot slope. The unlined excavation wall failed; fortunately, no waste was involved. Lesson: Operational error

can happen.

These lessons can be summarized by citing two old sayings:

“Nature sides with the hidden flaw”

and

*“No system is foolproof if you have
high enough caliber fools”*

PREVENTING SLIDES

To the geotechnical engineering profession, the slide problem is one in “slope stability analysis.” The history of rational slope stability analysis goes back to studies for the Swedish State Railways in 1927. The calculation methods are the same as we use for levees, dams, and natural slopes. The big differences for waste facilities are:

- Ⓒ The natures of the materials, both wastes and synthetics. While their strengths can be characterized by the Mohr-Coulomb failure criterion, these materials are *not* soils.
- Ⓒ The groundwater protection features we must build into these facilities often create planes of weakness.

Basic Idea. It’s really quite simple. Gravity tries to make the material fall downhill. The strength of the soil/waste/synthetic tries to hold the material up. We call the strength forces the “resisting forces” and the gravity forces the “driving forces.” We measure the stability of the slope by the ratio of the two:

$$\text{Safety Factor} = \text{Sum of Resisting Forces} / \text{Sum of Driving Forces}$$

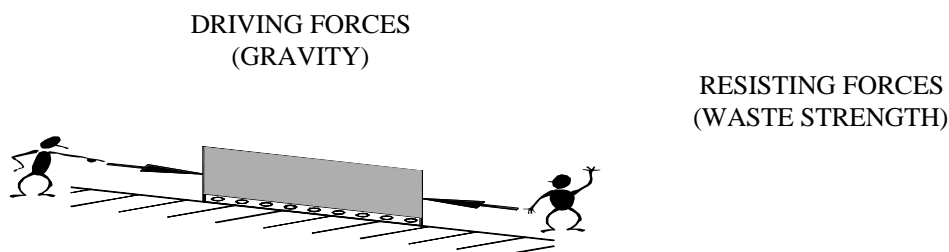

FIGURE 2 - GENERIC SLOPE STABILITY

In general, a safety factor near 1.0 means failure is likely. A safety factor of 1.3 commonly means a stable slope. In fact, the U.S. Army Corps of Engineers designs the levees for the lower Mississippi

River for a safety factor of 1.3, and the consequences of levee failure are enormous. For the far less disastrous case of a waste facility slide, regulators often require a 1.5 safety factor.

While the basic idea is simple, “*the devil is in the details,*” as you will see. As a general rule, however:

- Ⓒ A steep slope is less stable than a flat slope.
- Ⓒ A tall slope is less stable than a low slope (especially when clays are involved).
- Ⓒ “Ground” water conditions, including the water level in the waste mass itself, can dominate stability.

Two- or Three- Dimensional Analysis. Virtually every real slope stability problem has geometric components in three dimensions (3D). However, the complex problems of resolving the driving and resisting forces are simplified by assuming a two dimensional (2D) situation, i.e., plane strain. Almost all of the classical slope stability analysis are 2D models, and most computer codes use 2D methodology.

Does the 2D vs the 3D analysis situation really matter? Let’s look at a highly oversimplified model: a Coulomb block with a vertical face, in a purely cohesive material (See Figure 3):

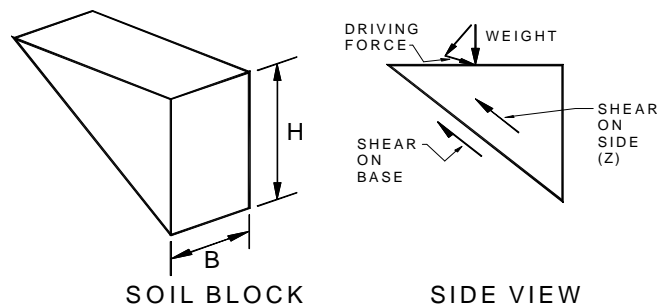

**FIGURE 3 -
SIMPLIFIED 3D MODEL**

The block’s weight gives us the driving force. The resisting force comes from shear along the bottom and sides of the block. A simple static analysis shows that

$$H_c = (4c/q)[1+(H_c/B)/2]$$

Where

H_c	=	Critical (failure) Height
c	=	Material Cohesion
q	=	Unit Weight of Material
B	=	Length of Block Along Face

The first term should be familiar to geotechnical engineers as the 2D Coulomb solution to this problem. We can then rearrange this in terms of safety factors for the 2D (SF_{2D}) and 3D (SF_{3D}) conditions:

$$SF_{3D} = SF_{2D} [1+(H/B)/2] \quad (\text{clay})$$

A similar simplified analysis for sand yields:

$$SF_{3D} = SF_{2D} (1+(H/B)^{2/3}) \quad (\text{sand})$$

Koerner and Soong (2000) defined the ratio (SF_{3D}/SF_{2D}) as the “wedge factor” (WF). Even these simple analyses show that $WF \geq 1$. Using a 2D analysis is therefore conservative - but, is it too conservative? Typical landfills might have heights of 150-250 feet and sides 1000-5000 feet long. The resulting (H/B) values are quite small, and lead to wedge factors on the order of 1.02 to 1.10. Neither mankind nor Mother Nature is so kind as to give us uniform materials. Limited areas of low strength result in higher effective (H/B) and (WF) values. Koerner and Soong (2000) report (WF) values for MSW landfills ranging from 1.06 to 1.25, and averaging about 1.16. So, if you have weaker areas you should define them areally and use a 3D analysis for the weaker condition.

Analysis Method. Whichever type of analysis we use, we have to determine the driving and resisting forces. To know the driving forces, we have to know the weight of the (potentially) sliding mass and the shape of the surface it’s trying to slide on. The resisting forces depend on these factors, and also on the shear strength acting along the surface the mass is trying to slide on. One minor problem - we seldom know exactly what that surface is!

So, the procedure is:

- ! Mentally isolate a block of the material. We know the slope of the top surface from design or a survey. The bottom surface may consist of planes, cylinders, log spirals, or a combination of them. We typically use a 2D-analysis, and work with a slice taken along the steepest section, as illustrated on Figure 4.

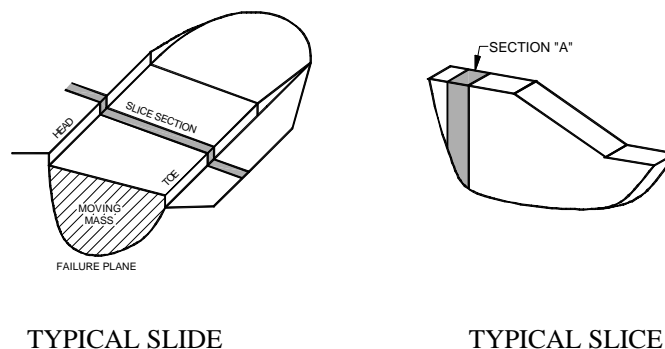

FIGURE 4 - FAILURE BLOCKS

- ! Calculate the driving forces (D) from the weights (W) of the different parts of the slice and their bottom slopes; see Figure 5.
- ! Calculate the resisting forces (R) due to the shear strength(s) of the material(s) along the bottom of the slice as shown in Figure 5.

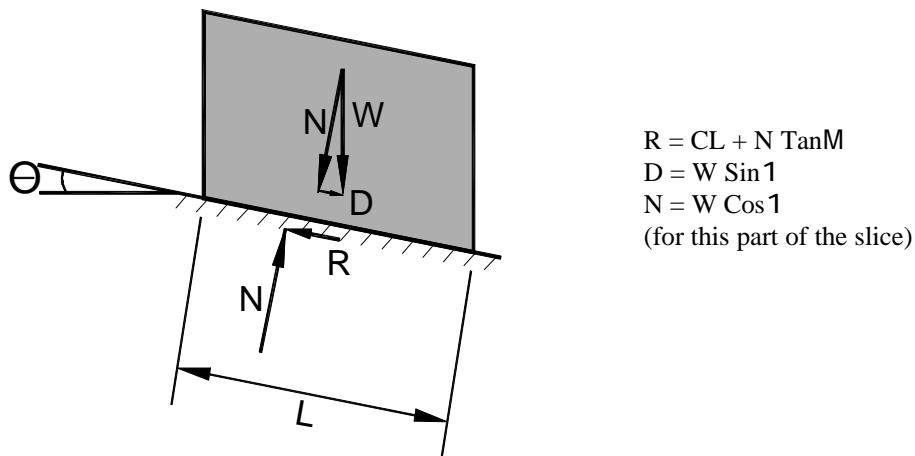

FIGURE 5 - FORCE RESOLUTION

- ! Get their ratio - the safety factor ($SF = R/D$).
- ! Try all over again with new blocks having different bottom shapes until we find the one with the lowest safety factor. Remember: “*Nature sides with the hidden flaw.*” The block (shape) with the lowest safety factor is therefore how the slope will try to fail, and is the best measure of stability.

The actual calculations are dull and laborious. Slope stability was, not surprisingly, the first geotechnical problem computerized. Today, there are several good 2D computer codes for this analysis, such as UTEXAS 3, PCSTABL, XTABL, etc., and most stability calculations are done by computer. One well-known 3D code is CLARA-1. However, remember the adage “Garbage In - Garbage Out” (terrible pun!). Your mathematical model of the slope stability situation must match reality. Setting up the problem for the computer should be done carefully and checked carefully. The code you use should not be a limiting factor in your analyses. Choose one that will handle several “soil” types, different potentiometric (“ground” water) regimes in different layers, and composite trial failure blocks, whose bottoms can be arcs, planes, and spirals, or combinations of them. The critical condition for relatively strong wastes (MSW, NHIW, Gypsum) on firm foundation soils is usually a slide along an interface with a plastic component (HDPE, Geonet). Check your output to see that the critical surface includes at least a partial section along the interface plane.

Material Strengths. Virtually all materials in a landfill and its man-made parts (like the plastics), behave somewhat like soils; at least their strengths follow the Mohr-Coulomb criterion for our purposes. Their

strengths will have one or both of the two components:

- ! Cohesion - It “sticks together,” like dough.
- ! Friction - The strength depends on how hard you push the material together, like when you rub two pieces of sandpaper together.

The plastics (geosynthetics) are a little different. It’s not their *internal* strengths that matter, but their cohesion and friction *against another material*. We measure friction by the “angle of internal friction” (N) for failure within a material, and by the “angle of interface friction” (*) for failure at the interface between two materials. A high friction angle indicates high strength, and vice-versa. The corresponding terms for the cohesion component are “cohesion” (c) and “adhesion” (a). The strengths are given by (See Figure 6):

$$S_o = c + p \tan N \quad (\text{internal})$$

$$S_i = a + p \tan * \quad (\text{interface})$$

p = Effective pressure acting against failure plane.

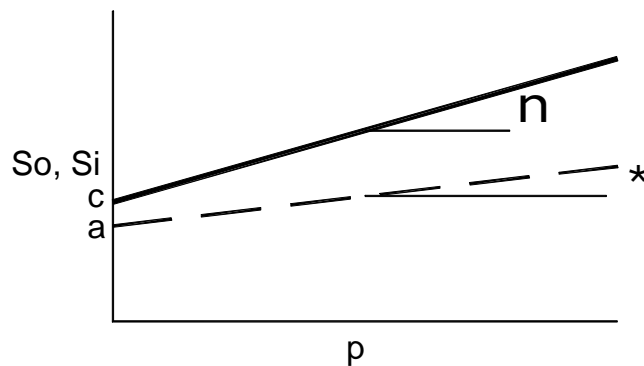

FIGURE 6 - MOHR'S DIAGRAMS FOR INTERNAL AND INTERFACE

MSW is a pretty strong material; assuming moderate compaction, its (S_o) is at least what you get with $c=300$ psf, $N=28^\circ$. These values are based on back-calculation of actual failures and large-scale shear box tests. Small-scale shear box tests reported in the literature yield higher, unconservative values. On a firm foundation, a very tall mass of MSW would be safe at a slope as steep as 1(V):2.5(H). The critical plane for MSW or HW landfills is normally along the (required) bottom geomembrane, which is usually composed of a plastic such as HDPE. For a smooth membrane against soil, (*) is about 15° ; it's as low as 10° for HDPE against a plastic drainage net. As an example, at the base of a 60-foot high pile of MSW, the shear strength of the MSW is some 2400 pounds per square foot, but only 900 pounds per square foot can act along the membrane-soil interface. Geosynthetic Clay Liners (GCL's) are being used frequently in liners and covers today. They are composed of bentonite, whose wetted friction angle

can be $10^\circ - 12^\circ$. In the situation described above, the shear strength of the GCL could be as low as 700 psf. Neglecting the interface and components situations can therefore lead to failure when you thought stability was adequate and met regulatory guidelines! We can improve the interface friction angle a few degrees by using textured HDPE. The improvement in stability can be worthwhile. For one 200-foot tall MSW landfill, the safety factor against a slide increased from 1.1 with a smooth HDPE bottom to 1.4 with textured HDPE.

Strain Compatibility. Most soils and wastes exhibit “strain softening.” When load is applied to any material, it deforms (slips or bends) a little. Add more load, and it deforms more. Finally, the material reaches its “peak strength.” Now the material keeps on deforming without an increase in its resistance to load. A strain-softening material keeps on deforming, but its load resistance actually drops to a constant, lower value: its “residual strength.” These concepts are illustrated on Figure 7.

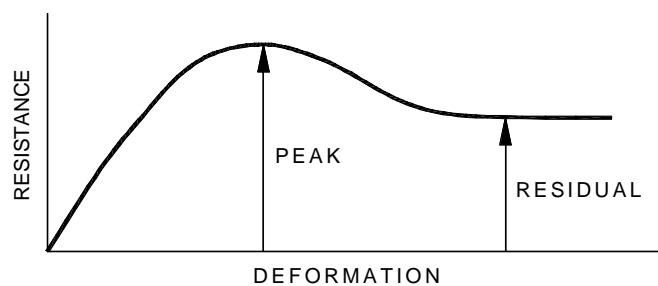

FIGURE 7 - STRAIN-SOFTENING MATERIAL

If all the materials involved in a landfill stability analysis reached their peak strengths at the same deformation, we could use their peak strengths for all materials in our analysis. Mother Nature is *not* so kind. For example, HDPE develops its peak interface strength at around 0.1 inch relative displacement. At that displacement, MSW will be developing only 20% to 30% of its peak strength. When the MSW finally reaches its peak strength at over 4 inches of relative displacement, the HDPE will have regressed to its residual strength (about 80-90% of its own peak strength). Similarly, at 4+ inches of displacement, most soils will be in their residual strength states, with strengths 50% - 80% of their peaks. These general behaviors are illustrated on Figure 8.

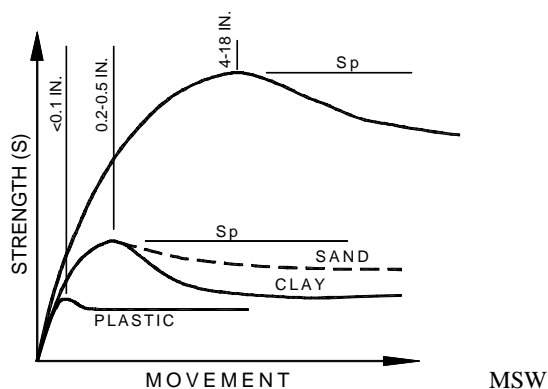

FIGURE 8 - LARGE STRAIN BEHAVIORS

A little thought leads to the following conclusions:

- C Using peak strengths for all materials will be unconservative, and,
- C Using residual strengths for all materials may be overconservative.

The best approach is using curves of developed strength vs displacement (like stress-strain curves) for each material. First, you select design strengths for all materials based on some low displacement (the same for all materials), and analyze the slope using these strengths. You'll get a low safety factor. Next, increase the displacement, which yields new design strengths, and rerun the analyses; the safety factor will increase. Repeat this procedure until a peak value of the safety factor is obtained; it will govern. Analyses of the simple landfill case shown on Figure 9 showed that the safety factor using all peak strengths was about 1.6. When strain compatibility was considered, the safety factor dropped to 1.4.

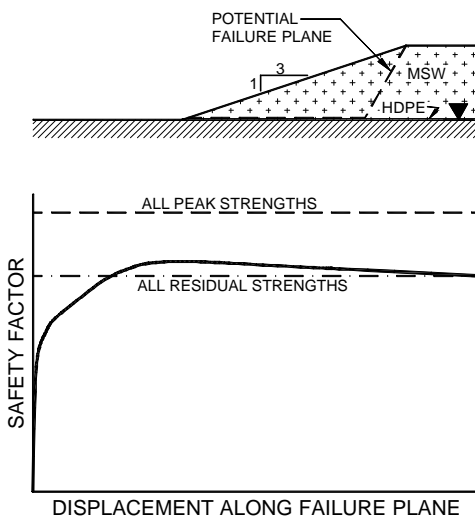

FIGURE 9 - SAFETY

FACTOR vs DISPLACEMENT

Material Density. The density of the waste is a major factor in both the driving forces and the resisting forces. Typically, the density of MSW is much lower than typical soils: 40-60 lb./cu.ft. vs 120 lb./cu.ft. The densities of papermill sludges are even less. MSW compresses sufficiently under its own self-weight to affect its density enough so that this effect must be considered. The density of MSW therefore depends not only on its as-placed density, but also on the thickness of the waste mass. Calculations using data from tests at the University of New Orleans (Depnath, 2000) show this effect, as illustrated on Figure 10.

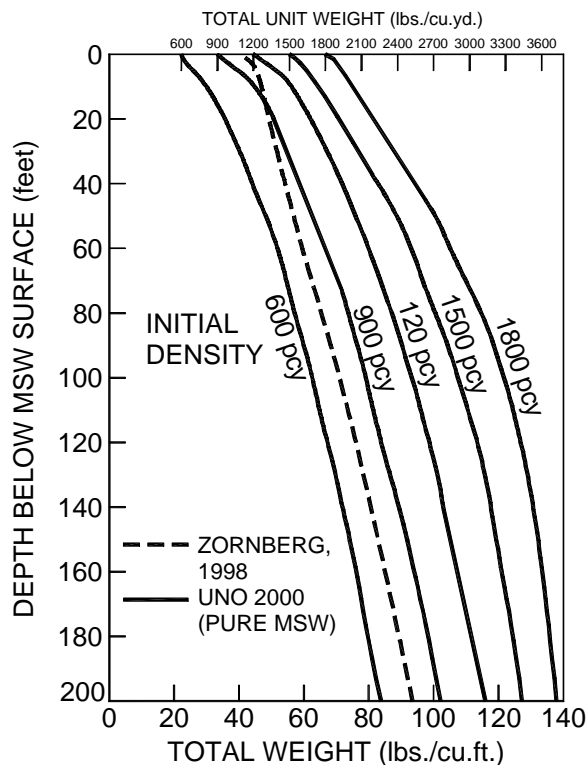

FIGURE 10 - MSW DENSITY vs DEPTH

A denser soil of a given type is stronger than one with a lower density. Soil strength increases in a roughly exponential manner with density. The same is true for MSW. While the denser MSW has a higher driving force, it also develops higher resisting forces. The Mohr-Coulomb parameters (c , k) are usually used to describe the shear strength of MSW. By taking a few semi-rational liberties with strength data presented in Kavazanjian (1995), the approximate relationships given on Figure 11 can be developed:

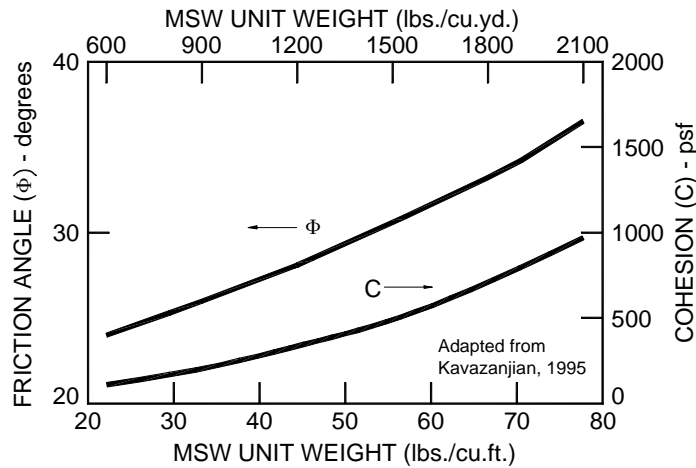

FIGURE 11 - MSW STRENGTH PARAMETERS vs DENSITY

So we have increasing density causing increases in both the driving forces and the resisting forces. What is the overall effect on stability? Let us take a simple example as given below, and take both effects of self-weight compression into account in the stability analyses. We have assumed that the MSW was compacted to initial (surface) densities corresponding to poor practice (600 lb./cu.yd.) through excellent practice (1500 lb./cu.yd.). The results are illustrated on Figure 12.

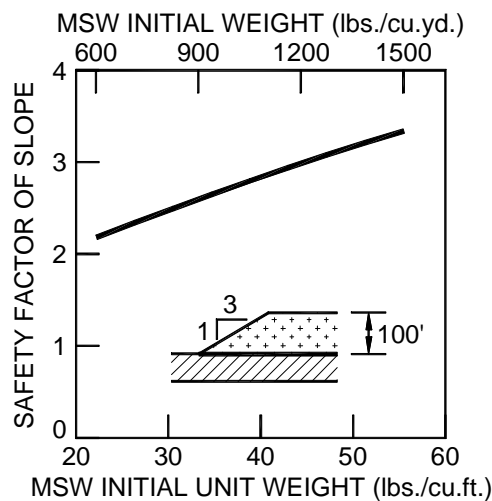

FIGURE 12 - EFFECT OF DENSITY ON STABILITY

Clearly, increasing the initial density increases the stability of the MSW landfill at a given slope. This could also mean increasing the side slope (and thus airspace) at a given safety factor.

Papermill sludges can have total densities less than that of water, i.e., will float. This material is also highly compressible, as much or more so than MSW. Gypsum residues, however, can have densities of 120-130 lb./cu.ft and are relatively incompressible.

Critical Case. You have to check the stability of *the most critical case*. What is this situation? We always analyze the stability of the final, closed landfill. However, this may not be the most critical situation. Many failures, including some mentioned earlier, were caused by operations. During operation, the waste mass can extend from the final height to the bottom of the excavation. This high slope usually exceeds the height of the completed landfill above surrounding grade, and can therefore be critical. These conditions are presented on Figure 13.

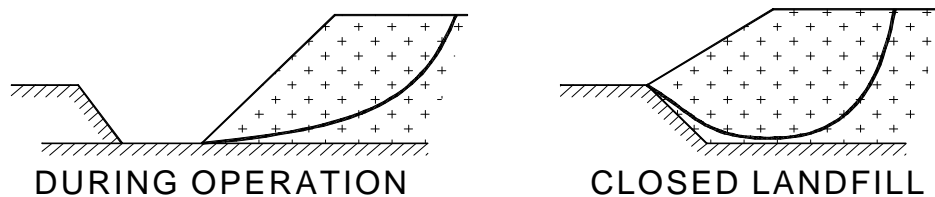

FIGURE 13 - CRITICAL HEIGHT

Excavation Slopes. You must also check the stability of excavation slopes. A failure here might not lead to contaminant release, but would destroy some expensive-to-replace liner system. The analysis method is the same as described before. However, this is usually a short-term condition involving normal soils as the likely failure zone. We therefore employ normal slope stability analysis techniques and use the in-situ natural soil strengths: the so-called “undrained” strengths.

BUILDING HIGH ON SOFT SOILS

Especially in Holocene alluvial deposits like those under south Louisiana and some parts of the East Coast, the waste and even the interfaces are stronger than the natural soils. Yet, there are landfills (for example, in the New Orleans area) which are behaving perfectly but are so tall and steep that they should have failed based on the strengths of the soils in the area! Why didn't they fail, and what does this tell us about new or expanded landfills?

Think about a mud puddle. As the mud dries (loses water), it gets stronger. Now, consider a sopping-wet sponge. If you squeeze it, water flows out. The same thing happens in soil under a landfill. When you build up the waste in the landfill, the pressure squeezes water out of the soil and the soil gets stronger. After some time, enough water has been squeezed out to increase soil strength to where you can apply more waste over the now-stronger foundation. This process, known as “controlled loading,” has been applied to large storage tanks on soft soils for over 40 years. It is a natural consequence of the Critical State Theory of Soil Mechanics. The detailed analyses are very complex, but have allowed us

to build landfills over 100 feet high where a 50 foot high landfill would cause failure without this methodology. A generic example is given on Figure 14.

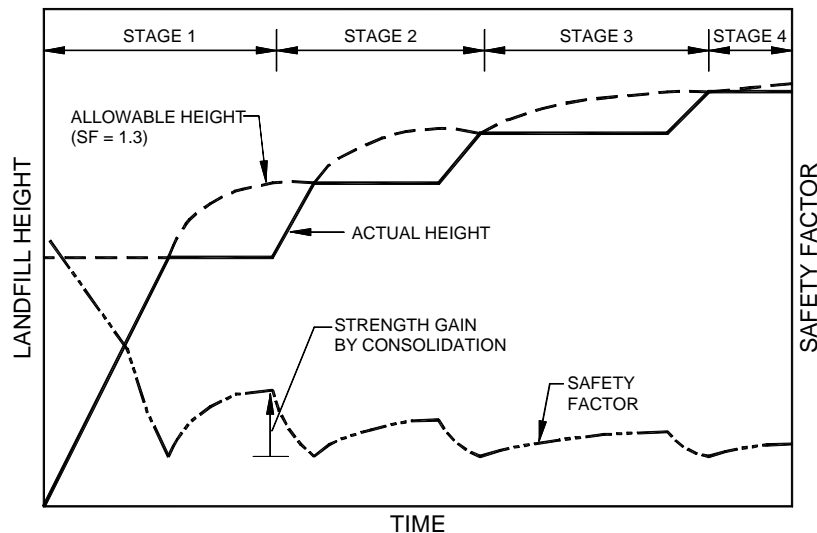

FIGURE 14 - CONTROLLED LOADING

OTHER WASTES

Most of the discussions so far have been for MSW landfills, and MSW is a strong material. However, there are many other types of materials which are placed into landfills or sludge impoundments. A few materials are discussed below.

Boiler Ash. Power plants produce mountains of ash. Fortunately, ash acts like a sand with a high friction angle (35° - 40°). The material itself is therefore relatively stable. The foundation soil or synthetic interfaces usually govern stability.

Gypsum. Both the Louisiana-Texas area and the North Carolina to Florida area have many fertilizer plants. Most fertilizer plants have huge stacks of waste gypsum. Some gypsums are like sands or gravels: high friction angles. Others are like strong clays (high cohesions), but may be brittle, i.e., highly strain-softening at low movements. In fact, the strength after cracking develops is no longer cohesive, but rather is from friction along the cracks. Stability is usually governed by the foundation soils unless they are quite strong. Stacks 100 feet high with side slopes of 1(V):3(H) have been stable even on the soft alluvial soils of south Louisiana. Stability usually requires controlled loading, and is monitored by inclinometers.

Spent Bauxite. This “red mud” is a by-product of aluminum plants and typically behaves like a very weak clay. Its strength is quite low, increasing from around 100-200 psf at its surface to near 300-500

psf at the 30 foot depth. Stability is usually governed by the waste itself. However, if the red mud is dewatered prior to its placement, stability is greatly improved.

Paper Mill Sludge. The strength of this material can be almost anything. Slopes at 1(V):4(H) have been stable; failures have occurred at 1(V):10(H). If the sludge is dried before placement, it is fairly strong. If it is placed wet, it can flow like syrup. Stability is usually governed by the material itself. Papermill sludges have fairly good friction angles (25° - 35°), but low densities (45-65 pcf). If there is a water table in the sludge mass, the *effective* pressure (total pressure minus water pressure) will be low. The sludge's strength (which resists movement) depends on the effective pressure, so will also be low. The driving forces, however, depend on the *total* pressures. Thus, the driving forces can be high and the resisting forces low; the result is a low safety factor. As an example, a dry sludge landfill can be stable on a slope as steep as 1(V):1.7(H). A saturated sludge landfill can fail on a slope of 1(V):12(H) or even flatter. An analysis for a typical but simplified situation is illustrated on Figure 15.

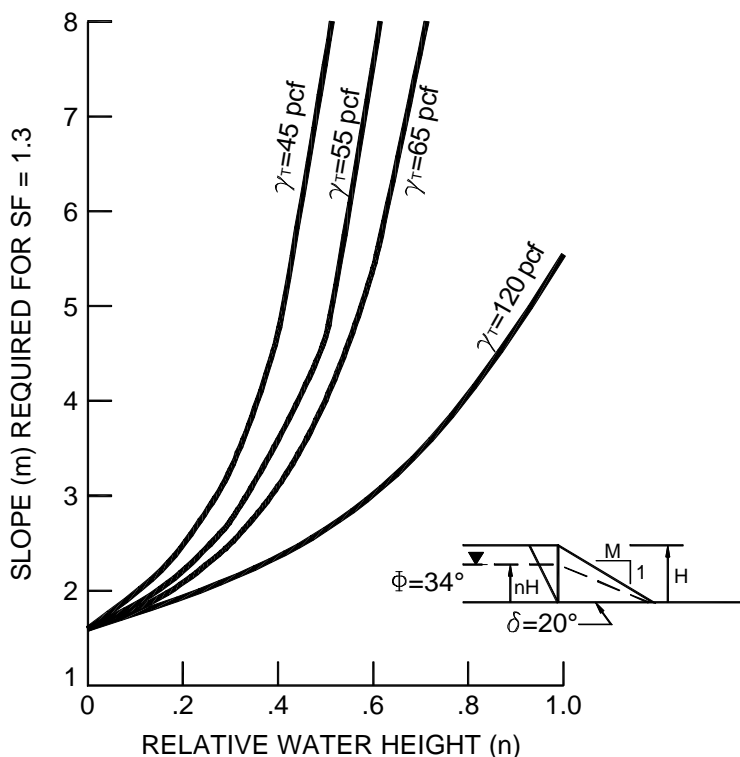

FIGURE 15 - SLUDGE LANDFILL STABILITY

Water control is the key to sludge landfill stability. Reducing the water pressures increases the effective stresses, making the sludge stronger. To accomplish pressure relief, the surface should have a cover to inhibit infiltration. Horizontal drainage blankets about 10 feet apart vertically control the water pressure buildup to a safe level. The Pacific Northwest slide mentioned earlier was successfully stabilized by (1)

wick drain dewatering of the existing mass, and (2) drainage blankets for the new sludge.

WHAT DOES ALL THIS MEAN?

- ! Wasteslides have occurred, usually as a result of neglecting the interface problem or because of improper operations. The results have ranged from annoying to highly embarrassing.
- ! Standard engineering analysis methods can be used to attain proper stability.
- ! Be sure to check all likely modes of failure, especially at interfaces.
- ! Wastes are not soils. Their strength properties vary from hard (gypsum) to almost fluid (some sludges), and their compressibilities from virtually incompressible to highly compressible. The proper strength characteristics must be used, and strain compatibility must often be considered.